



**baby lock**<sup>®</sup>

*espire*<sup>®</sup>

**Quick  
Reference  
Guide**

*Guide de  
Référence  
Rapide*

*Guía rápida  
del Referencia*

Model BLSR

Baby Lock Consumer Helpline: 800-313-4110  
[www.babylock.com](http://www.babylock.com)

Refer to the instruction manual for detailed instructions.

Also, there are differences in the keys and screens depending on the display language. In this guide, English screens are used for basic explanations.

Pour les instructions détaillées, voir le mode d'emploi.

Par ailleurs, il y a des différences dans les touches et les écrans en fonction de la langue d'affichage.

Dans ce guide, les explications de base utilisent les écrans anglais.

Consulte el manual de instrucciones para ver más detalles.

Además, dependiendo del idioma visualizado algunos botones y pantallas podrán ser diferentes.

En esta guía, para las explicaciones básicas se emplean pantallas en inglés.

**<English display>**  
**<Affichage en Anglais>**  
**<Visualización en inglés>**

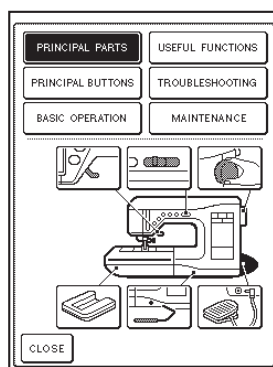

**<Example: French>**  
**<Exemple : Français>**  
**<Ejemplo: Francés>**

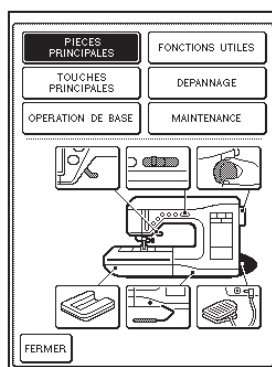

**<Example: Spanish>**  
**<Exemple : Español>**  
**<Ejemplo: Español>**

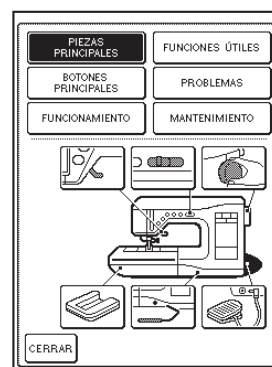

## Contents

<b>Advanced Sewing Features</b> .....	<b>2</b>
I) Pivoting .....	2
II) Automatic Fabric Sensor System (Automatic Presser Foot Pressure).....	2
III) Back to Beginning Key .....	3
IV) Automatic Drop Feed (Button attaching) .....	3
V) Automatic Drop Feed (Free-motion Mode).....	4
VI) Automatic Fabric Sensor System (Free Motion) .....	4
VII) Free Motion Foot Height .....	4
VIII) Quilting Feet (Free-Motion) .....	5
-Free-motion quilting foot "C" .....	5
-Free-motion echo quilting foot "E" .....	5
-Free-motion open toe quilting foot "O" .....	6
<b>Winding the Bobbin</b> .....	<b>7</b>
<b>Setting the Bobbin</b> .....	<b>7</b>
<b>Upper Threading</b> .....	<b>8</b>
<b>Selecting Stitch Patterns</b> .....	<b>9</b>
Utility Stitches .....	9
Character/Decorative Stitches .....	9
Others .....	10
<b>Summary of Stitch Patterns</b> .....	<b>11</b>
Utility Stitches.....	11
Character/Decorative Stitches .....	12

## Table des matières

<b>Fonctions exceptionnelles</b> .....	<b>2</b>
I) Pivotement .....	2
II) Système de détection automatique du tissu (pression automatique du pied-de-biche).....	2
III) Retour à la touche de début .....	3
IV) Entraînement automatique par griffe (fixation de boutons) .....	3
V) Entraînement par griffe automatique (mode en mouvement libre) ....	4
VI) Système de détection automatique du tissu (mouvement libre) .....	4
VII) Hauteur du pied pour la couture en mouvement libre .....	4
VIII) Pied de quilting (mouvement libre) .....	5
-Pied pour quilting en mouvement libre "C" .....	5
-Pied pour quilting en écho en mouvement libre "E" .....	5
-Pied pour quilting ouvert en mouvement libre "O" .....	6
<b>Bobinage de la canette</b> .....	<b>7</b>
<b>Mise en place de la canette</b> .....	<b>7</b>
<b>Enfilage supérieur</b> .....	<b>8</b>
<b>Sélection des configurations de point</b> .....	<b>9</b>
Points utilitaires.....	9
Caractères/points décoratifs .....	9
Autres .....	10
<b>Sommaires des motifs de point</b> .....	<b>11</b>
Points utilitaires.....	11
Caractères/points décoratifs .....	12

## Contenido

<b>Funciones excepcionales</b> .....	<b>2</b>
I) Función de giro .....	2
II) Sensor automático de tela (Presión automática del pie prensatela) .....	2
III) Tecla Volver al principio .....	3
IV) Selector automático de dientes de arrastre (costura de botones) .....	3
V) Selector automático de dientes de arrastre (Modo de costura libre) .....	4
VI) Sensor automático de tela (libre) .....	4
VII) Altura del pie para costura libre .....	4
VIII) Pie para acolchado (libre) .....	5
-Pie para acolchado libre "C" .....	5
-Pie para acolchado repetido libre "E" .....	5
-Pie para acolchado libre de punta abierta "O" .....	6
<b>Devanado de la bobina</b> .....	<b>7</b>
<b>Colocación de la bobina</b> .....	<b>7</b>
<b>Hilo superior</b> .....	<b>8</b>
<b>Selección de tipos de puntada</b> .....	<b>9</b>
Puntadas útiles .....	9
Puntadas de letras/decorativas .....	9
Otros .....	10
<b>Resumen de tipos de puntada</b> .....	<b>11</b>
Puntadas útiles .....	11
Puntadas de letras/decorativas .....	12

# Advanced Sewing Features

## Fonctions exceptionnelles

## Funciones excepcionales

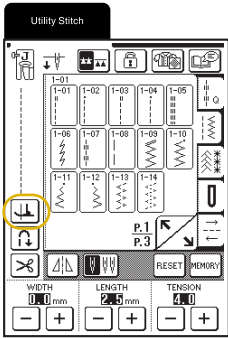

### ◆I) Pivoting

The function is useful when changing the sewing direction. The machine stops with the needle lowered (in the fabric) and the presser foot is automatically raised to an appropriate height when the “Start/Stop” button is pressed. The presser foot can be adjusted to one of three heights (3.2mm, 5.0mm and 7.5mm) through the setting screen “PIVOTING HEIGHT”.

### ◆I) Pivotement

Cette fonction est utile lors du changement du sens de la couture. La machine s'arrête, l'aiguille abaissée (dans le tissu), et le pied-de-biche se relève automatiquement à une hauteur appropriée lorsque la touche “Marche/Arrêt” est enfoncée. Vous pouvez ajuster la hauteur du pied-de-biche sur l'une des trois hauteurs disponibles (3,2 mm, 5,0 mm et 7,5 mm) à l'aide de l'écran de réglage “HAUTEUR DE PIVOTEMENT”.

### ◆I) Función de giro

Esta función resulta útil cuando se cambia la dirección de costura. La máquina se detiene con la aguja en posición baja (dentro de la tela) y el pie prensatela se eleva automáticamente hasta una altura adecuada cuando se pulsa el botón de “inicio/parar”. El pie prensatela se puede ajustar en una de tres alturas (3,2 mm, 5,0 mm o 7,5 mm) en la pantalla de ajustes “ALTURA DE GIRO”.

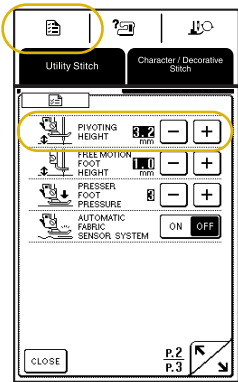
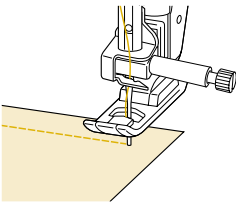

### ◆II) Automatic Fabric Sensor System (Automatic Presser Foot Pressure)

The presser foot automatically senses the fabric thickness and adjusts the pressure for smooth and even feeding of the fabric. This function is useful for sewing over thick seams and piecing or patchwork quilting (not applicable for free-motion sewing).

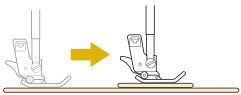

### ◆II) Système de détection automatique du tissu (pression automatique du pied-de-biche)

Le pied-de-biche détecte automatiquement l'épaisseur du tissu et ajuste la pression pour garantir un entraînement homogène et régulier du tissu. Cette fonction s'avère utile pour la réalisation de coutures épaisses et de quilting d'assemblage et de patchwork (non applicable à la couture en mouvement libre).

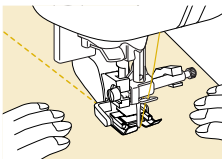

### ◆II) Sensor automático de tela (Presión automática del pie prensatela)

El pie prensatela detecta automáticamente el grosor de la tela y ajusta la presión para que la tela avance fácilmente. Esta función resulta útil para coser encima de costuras gruesas y remiendos o acolchado (no puede utilizarse para la costura libre).

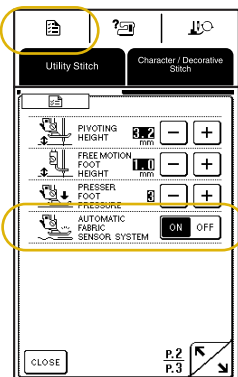

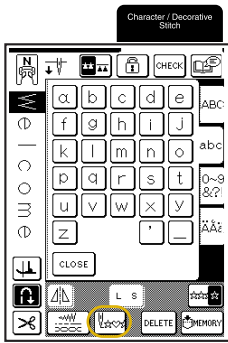

### ◆III) Back to Beginning Key

If the machine stops in the middle of sewing a combined stitch pattern, press this key to restart sewing from the beginning of the pattern. (In this example, sewing begins from “W”). In addition, if this key is pressed when sewing is stopped, patterns can be added at the end of a combined stitch pattern. (In this example, “!” is added.)

### ◆III) Retour à la touche de début

Si la machine s'arrête au milieu de la couture d'un motif de points combinés, appuyez sur cette touche pour reprendre la couture depuis le début du motif. (Dans cet exemple, la couture commence à partir de “W”). En outre, si vous appuyez sur cette touche lorsque la couture est arrêtée, des motifs peuvent être ajoutés après le motif de point combiné initial. (Dans cet exemple, “!” est ajouté.)

### ◆III) Tecla Volver al principio

Si la máquina se detiene en mitad de la costura de un patrón combinado, pulse esta tecla para volver a comenzar la costura desde el principio. (En este ejemplo, la costura comienza en “W”). Además, si se pulsa esta tecla con la costura detenida, se pueden añadir patrones después del patrón combinado original. (En este ejemplo, se ha añadido “!”).

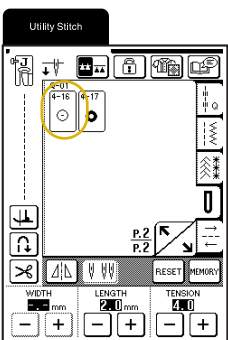
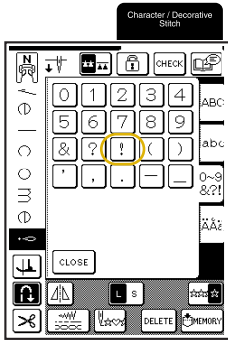
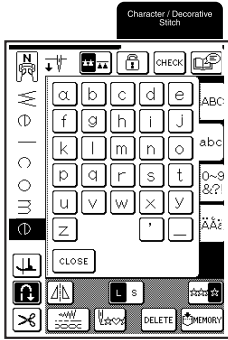

### ◆IV) Automatic Drop Feed (Button attaching)

Attaching a button is very simple when using this feature. Select button sewing stitch 4-16 and the feed dog is automatically lowered.

### ◆IV) Entraînement automatique par griffe (fixation de boutons)

Coudre un bouton est très simple grâce à cette fonction. Sélectionnez le point de couture de boutons 4-16. La griffe d'entraînement est automatiquement abaissée.

### ◆IV) Selector automático de dientes de arrastre (costura de botones)

Con esta función la costura de botones resulta muy fácil. Seleccione la puntada para costura de botones 4-16 y los dientes de arrastre se bajan automáticamente.

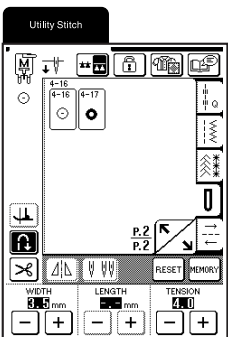

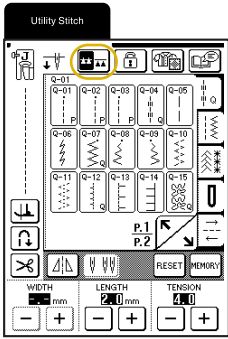

#### ◆V) Automatic Drop Feed (Free-motion Mode)

This function is useful for free-motion quilting. Touch the drop feed key and the feed dogs are automatically lowered so that the fabric can be moved freely. The presser foot height is raised and the upper thread tension is automatically adjusted for free-motion sewing.

#### ◆V) Entraînement par griffe automatique (mode en mouvement libre)

Cette fonction est utile pour le quilting en mouvement libre. Appuyez sur la touche d'entraînement par griffe et les griffes d'entraînement sont automatiquement abaissées de façon à pouvoir déplacer librement le tissu. La hauteur du pied-de-biche est augmentée et la tension du fil supérieur est automatiquement ajustée pour la couture en mouvement libre.

#### ◆V) Selector automático de dientes de arrastre (Modo de costura libre)

Esta función resulta útil para el acolchado libre. Pulse la tecla de dientes de arrastre y estos se bajarán automáticamente para que pueda mover la tela en cualquier dirección. Se aumenta la altura del pie prensatela y se ajusta automáticamente la tensión del hilo superior para la costura libre.

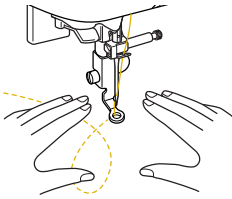

#### ◆VI) Automatic Fabric Sensor System (Free Motion)

When starting to sew with the quilting foot "C" or the echo quilting foot "E", the foot will automatically sense the fabric and adjust to the preset height of the foot for free motion sewing.

#### ◆VI) Système de détection automatique du tissu (mouvement libre)

Lorsque vous commencez à coudre avec le pied de quilting "C" ou le pied d'écho quilting "E", le pied détecte automatiquement le tissu et ajuste sa hauteur pour la couture en mouvement libre.

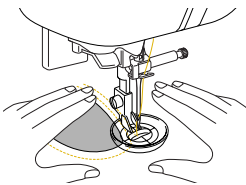

#### ◆VI) Sensor automático de tela (libre)

Cuando comienza a coser con el pie para acolchado "C" o el pie para acolchado repetido "E", el pie detectará automáticamente la tela y se ajustará en la altura especificada del pie para costura libre.

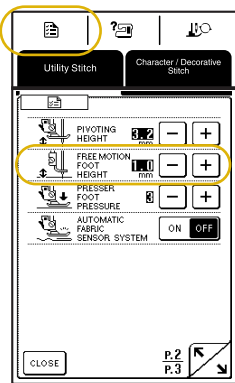

#### ◆VII) Free Motion Foot Height

When using the quilting foot "C" or the echo quilting foot "E", the height of the foot can be preset in the setting screen. Height of the presser foot can be increased for easy fabric guiding when sewing puffy and thick fabrics or decreased for better control of thin fabrics.

#### ◆VII) Hauteur du pied pour la couture en mouvement libre

Lors de l'utilisation du pied de quilting "C" ou du pied d'écho quilting "E", vous pouvez pré régler la hauteur du pied dans l'écran de réglage. Vous pouvez augmenter la hauteur du pied-de-biche pour guider plus facilement le tissu lors de la couture de tissus épais ou de mousse, ou la réduire pour coudre plus aisément des tissus fins.

#### ◆VII) Altura del pie para costura libre

Cuando vaya a utilizar el pie para acolchado "C" o el pie para acolchado repetido "E", la altura del pie se puede especificar en la pantalla de ajustes. La altura del pie prensatela se puede aumentar para guiar la tela más fácilmente, cuando vaya a coser telas gruesas y abultadas, o disminuir para un mejor control de telas finas.



◆VIII) Quilting Feet (Free-Motion)

◆VIII) Pied de quilting (mouvement libre)



◆VIII) Pie para acolchado (libre)





**Free-motion quilting foot “C”**

This presser foot is used to create better free-motion sewing results with straight stitching. Be sure to select a straight stitch with the middle (center) needle position (  or  ).

**Pied pour quilting en mouvement libre “C”**



Ce pied-de-biche permet d'obtenir de meilleurs résultats de couture en mouvement libre à l'aide de points droits. Veuillez à sélectionner un point droit, l'aiguille positionnée au milieu (  ou  ).

**Pie para acolchado libre “C”**

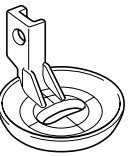
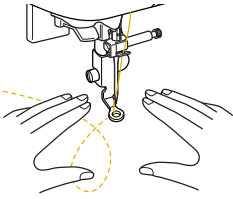

Este pie prensatela permite obtener mejores resultados con la costura libre en línea recta. Asegúrese de seleccionar una puntada recta con la aguja en el medio (centro) (  o  ).





**Free-motion echo quilting foot “E”**

This presser foot is used to create stitching at a fixed distance from a motif outline or stitching, for example, with echo quilting. Select a straight stitch with the middle (center) needle position (  or  ), and sew using the measurements on the presser foot as a guide.

**Pied pour quilting en écho en mouvement libre “E”**

Ce pied-de-biche permet de créer une couture à distance constante à partir du contour d'un motif ou de la couture, par exemple à l'aide du quilting en écho. Sélectionnez un point droit, l'aiguille positionnée au milieu (  ou  ), et cousez en utilisant les mesures indiquées sur le pied-de-biche comme guide.

**Pie para acolchado repetido libre “E”**

Este pie prensatela sirve para coser a una distancia fija del contorno de un motivo o costura, por ejemplo, con el acolchado repetido. Seleccione una puntada recta con la aguja en el medio (centro) (  o  ) y cosa guiándose con las medidas del pie prensatela.

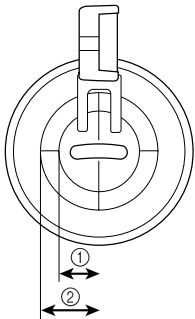

- ① 6.4 mm  
(approx. 1/4 inch)
- ② 9.5 mm  
(approx. 3/8 inch)

- ① 6,4 mm  
(env. 1/4 de pouce)
- ② 9,5 mm  
(env. 3/8 de pouce)

- ① 6,4 mm  
(aprox. 1/4 pulg.)
- ② 9,5 mm  
(aprox. 3/8 pulg.)

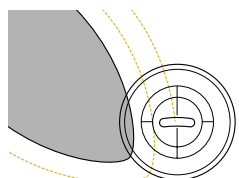
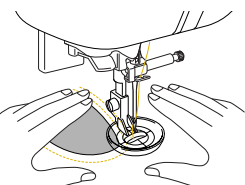

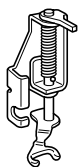

**Free-motion open toe quilting foot “O”**

This presser foot is used for free-motion quilting with a zigzag or for free-motion quilting of straight stitching on fabric with an uneven thickness.

**Pied pour quilting ouvert en mouvement libre “O”**

Ce pied-de-biche est utilisé pour le quilting en mouvement libre avec zigzag ou le quilting en mouvement libre avec point droit sur un tissu dont l'épaisseur n'est pas uniforme.

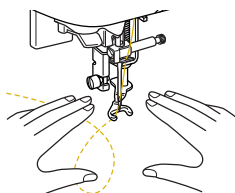

**Pie para acolchado libre de punta abierta “O”**

Este pie prensatela sirve para el acolchado libre con una puntada de zigzag o para líneas rectas en tela con un grosor irregular.

# Winding the Bobbin

## Bobinage de la canette

### Devanado de la bobina

Follow the numbered steps below in order. Refer to the instruction manual for detailed instructions.  
 Suivez les étapes numérotées ci-dessous dans l'ordre. Consultez le manuel d'instructions pour des procédures détaillées.  
 Realice los siguientes pasos numerados en el orden indicado. Para obtener instrucciones detalladas, consulte el manual de instrucciones.

Use only the enclosed bobbin or bobbins of the same type.  
 N'utilisez que la canette fournie ou des canettes du même type.  
 Utilice sólo la bobina incluida o bobinas del mismo tipo.

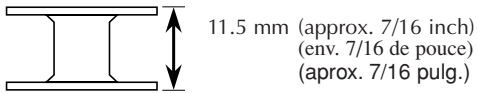

#### Using the Supplemental Spool Pin

You can wind the bobbin during sewing.

#### Utilisation du porte-bobine supplémentaire

Vous pouvez bobiner la canette pendant la couture.

#### Uso del portacarrete suplementario

Puede devanar la bobina mientras está cosiendo.

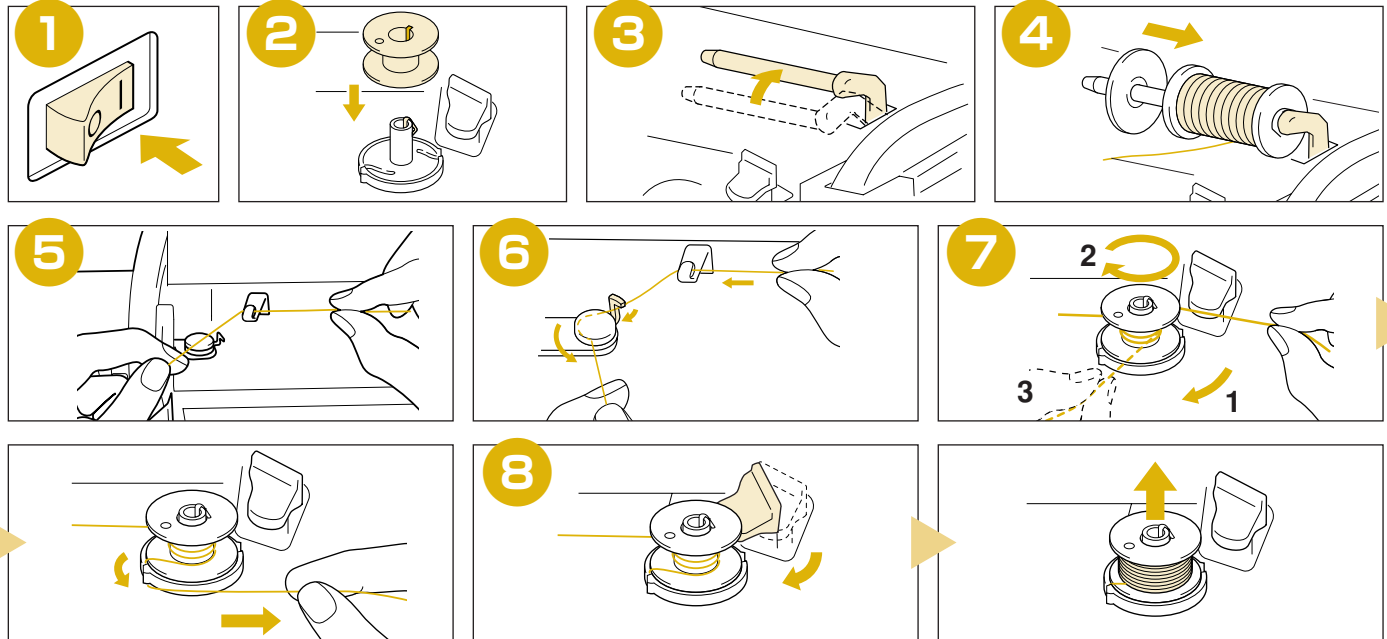
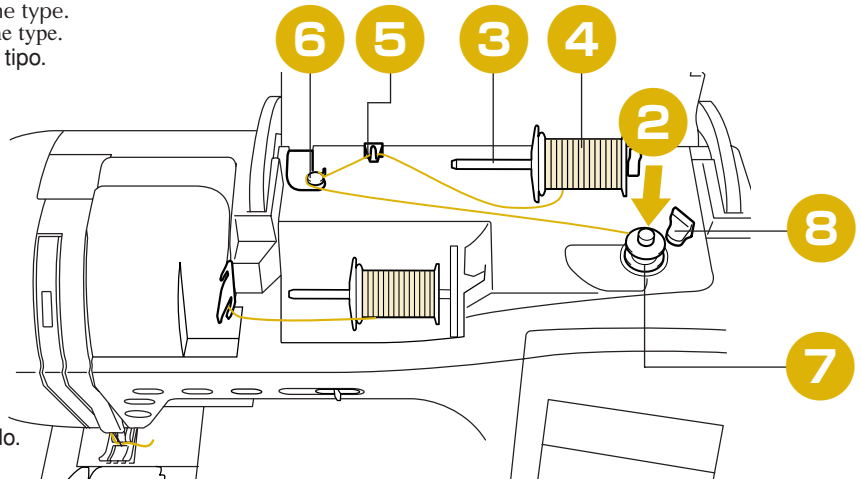

# Setting the Bobbin

## Mise en place de la canette

### Colocación de la bobina

Refer to the instruction manual for detailed instructions.  
 Pour les instructions détaillées, voir le mode d'emploi.  
 Consulte el manual de instrucciones para ver más detalles.

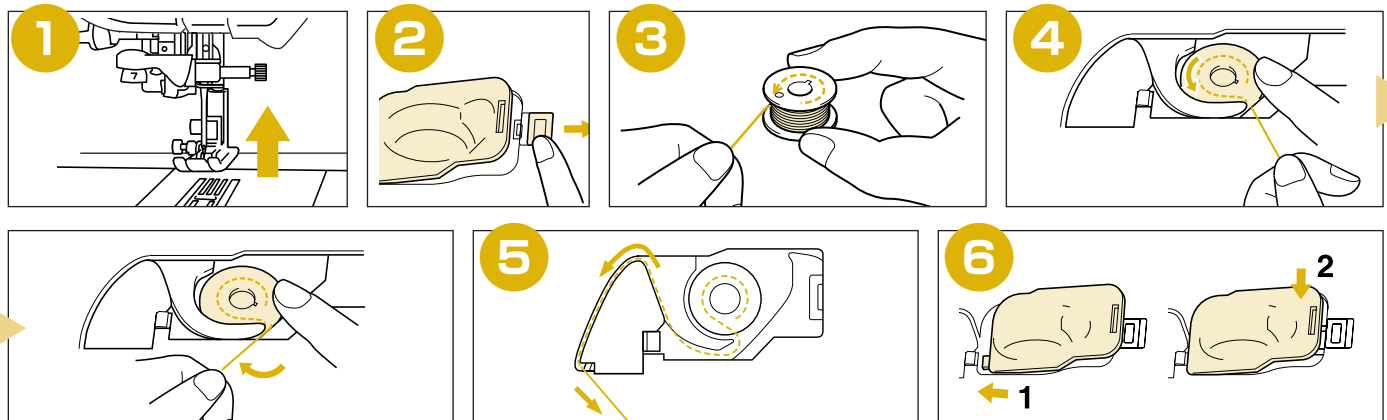

# Upper Threading

## Enfilage supérieur

### Hilo superior

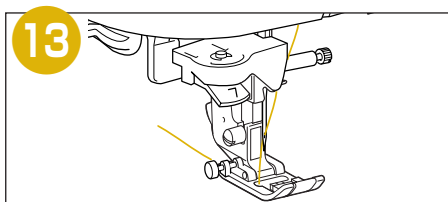
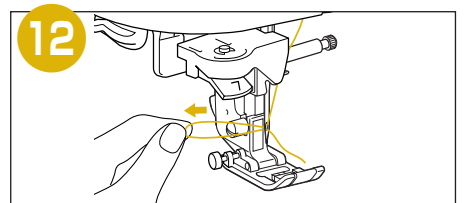
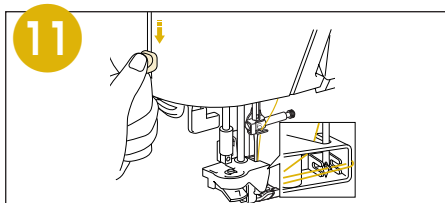
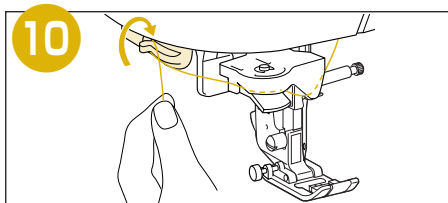
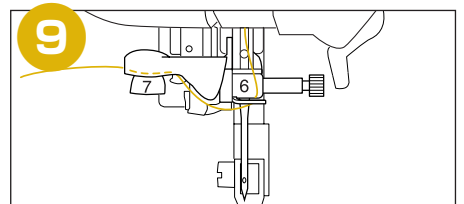
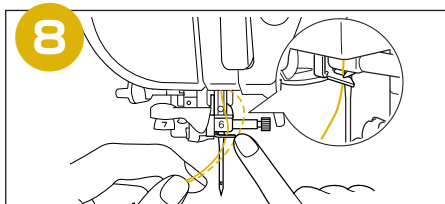
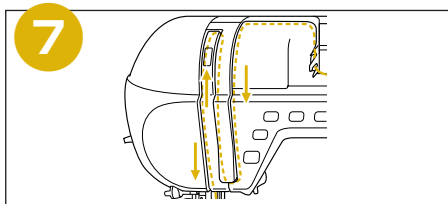
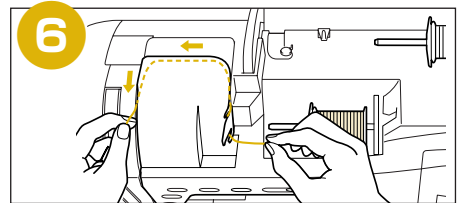
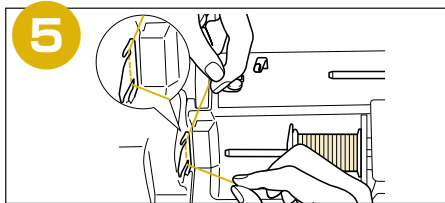
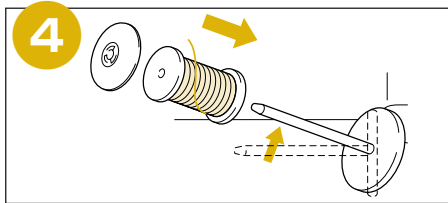
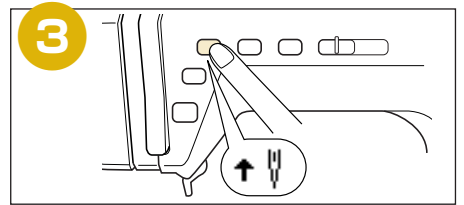
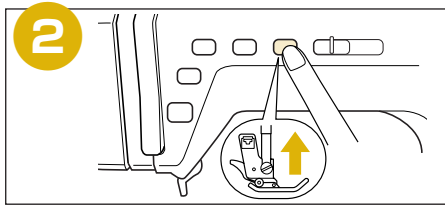
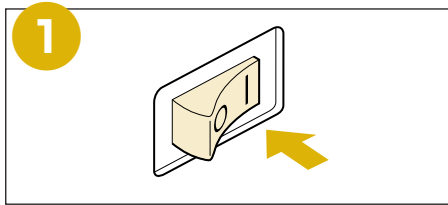
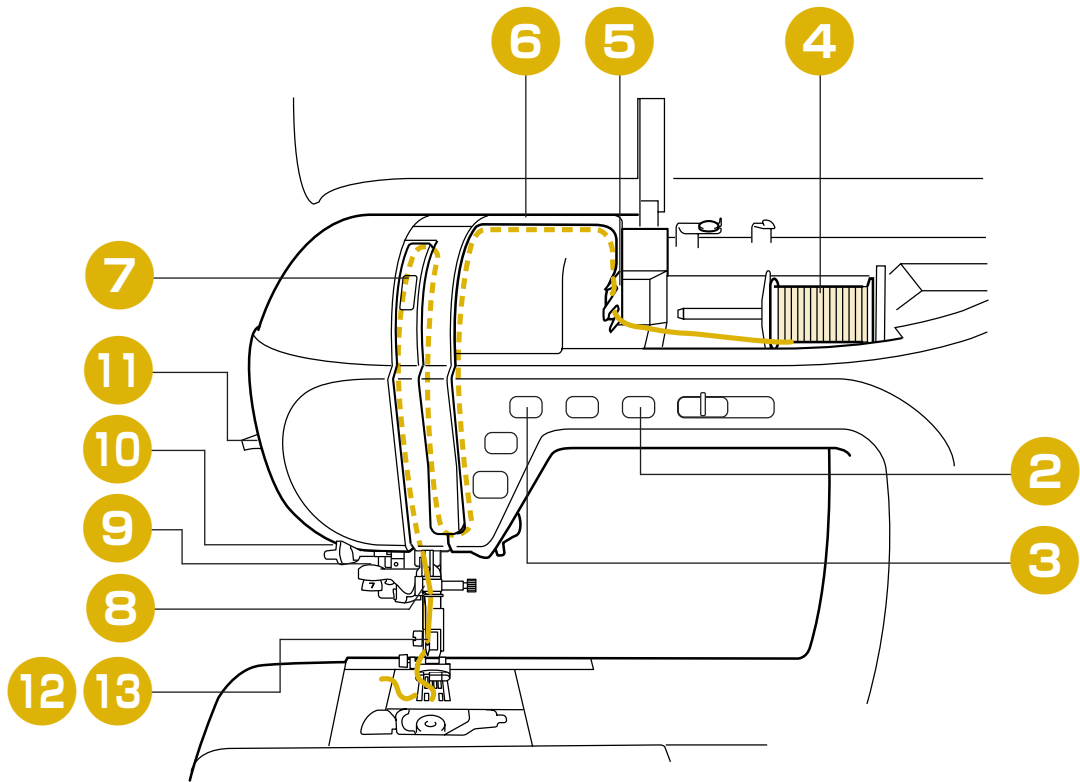

# Selecting Stitch Patterns

## Sélection des configurations de point

## Selección de tipos de puntada

### ◆ Utility Stitches

When switching on machine, the screen will display the opening screen. Touch the screen to display the utility stitch. Depending on the setting, either “Q-01 Piecing Stitch (Middle)”, “1-01 Straight stitch (Left)” or “1-03 Straight stitch (Middle)” is automatically selected.

### ◆ Points utilitaires

Lorsque vous mettez la machine sous tension, l'écran d'accueil s'affiche. Touchez l'écran pour afficher le point de couture courant. Selon le réglage, “Q-01 Point d'assemblage (milieu)”, “1-01 Point droit (gauche)” ou “1-03 Point droit (milieu)” est automatiquement sélectionné.

### ◆ Puntadas utiles

Cuando se enciende la máquina, aparece la pantalla de presentación. Toque la pantalla para mostrar la puntada de utilidad. En función del ajuste se seleccionará automáticamente “Q-01 Puntada para remendar (medio)”, “1-01 Puntada recta (izquierda)” o “1-03 Puntada recta (medio)”.

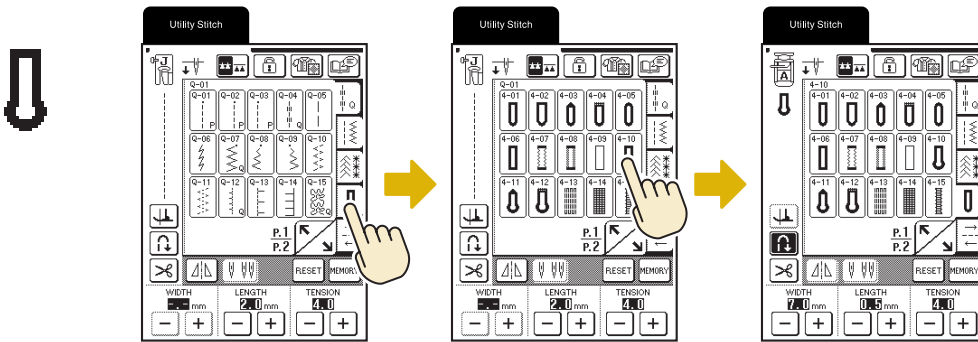

### Blind Hem Stitch / Points invisibles / Puntada invisible

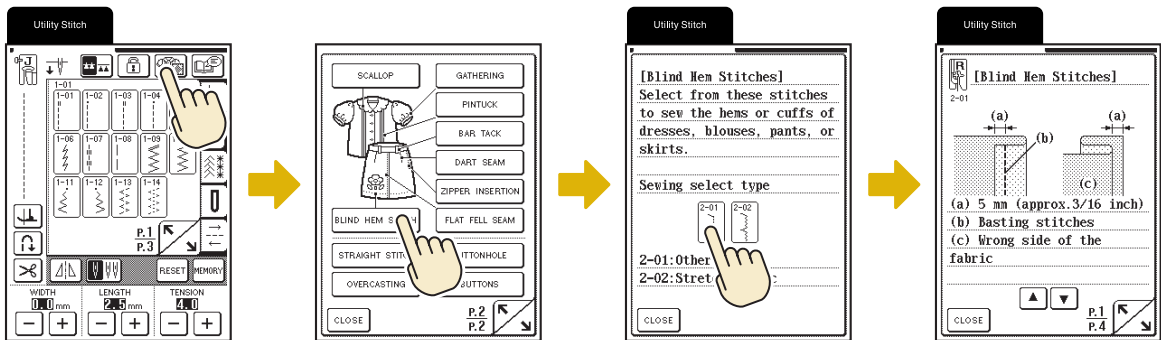

### ◆ Character/Decorative Stitches

### ◆ Caractères/points décoratifs

### ◆ Puntadas de letras/decorativas

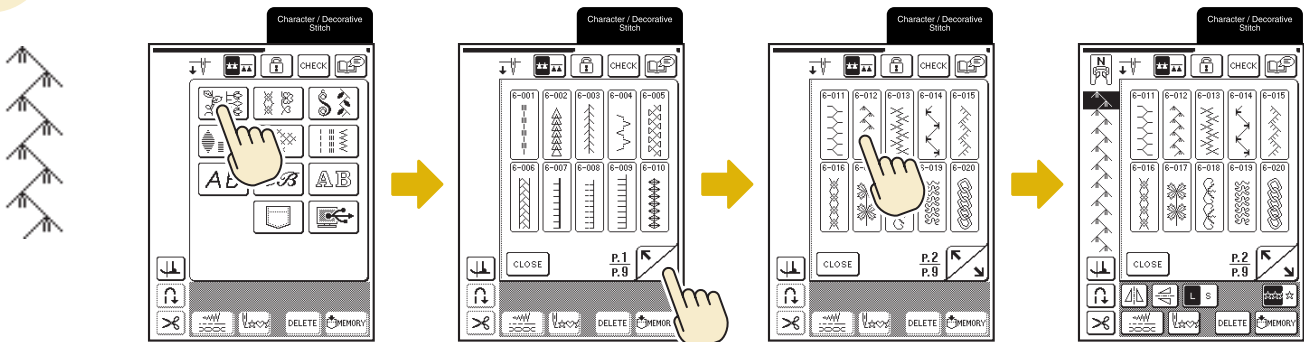

- ◆ Others
- ◆ Autres
- ◆ Otros

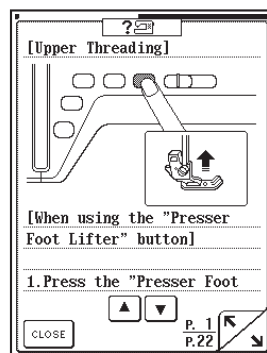
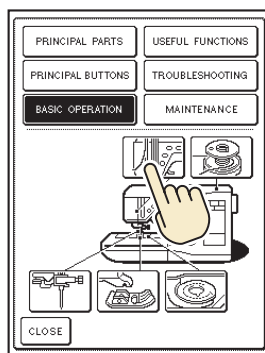
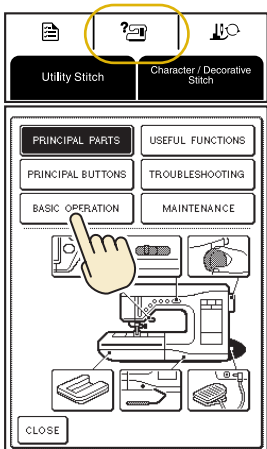
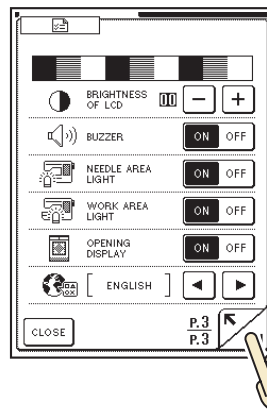
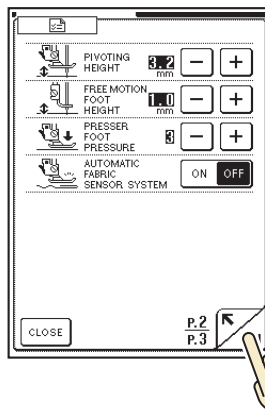
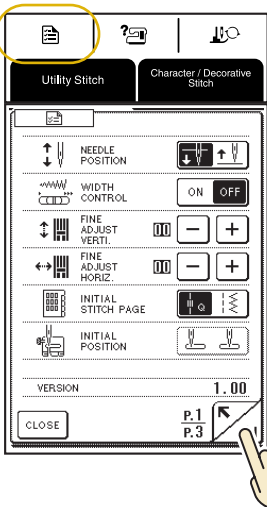
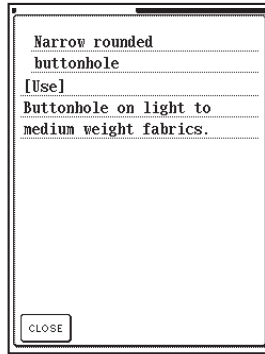
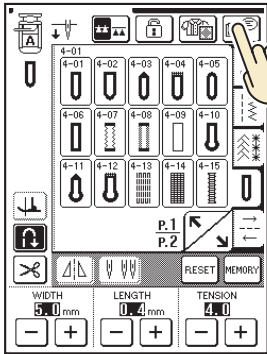

# Summary of Stitch Patterns

## Sommaires des motifs de point

### Resumen de tipos de puntada

- ◆ Utility Stitches
- ◆ Points utilitaires
- ◆ Puntadas utiles

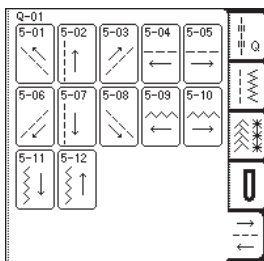
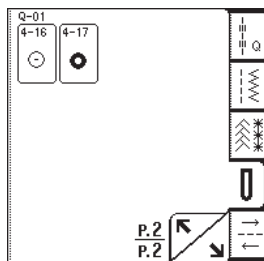
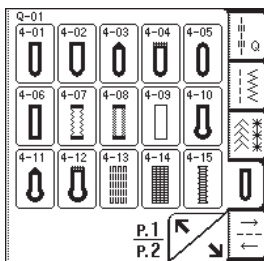
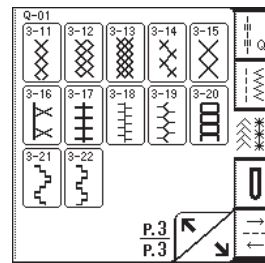
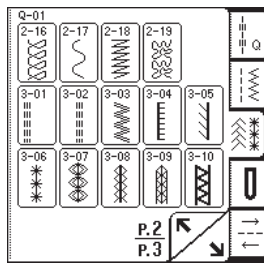
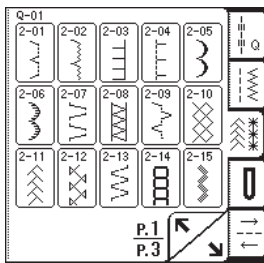
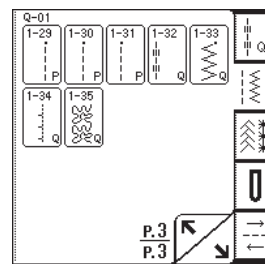
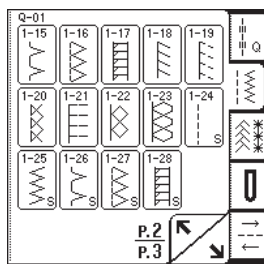
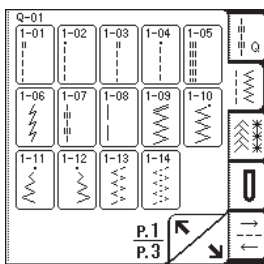
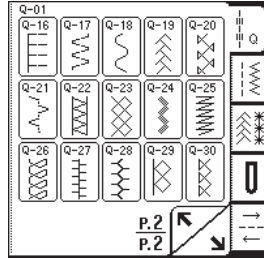
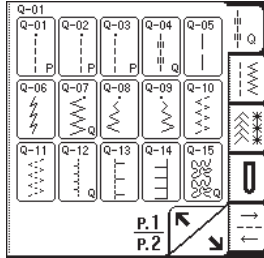
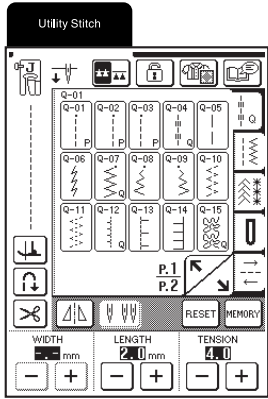

- ◆ Character/Decorative Stitches
- ◆ Caractères/points décoratifs
- ◆ Puntadas de letras/decorativas

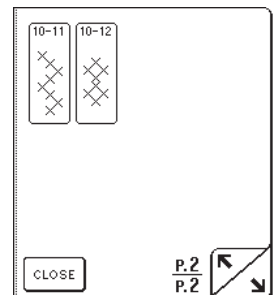
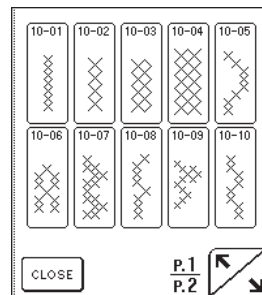
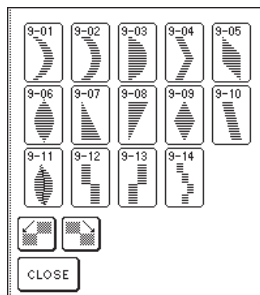
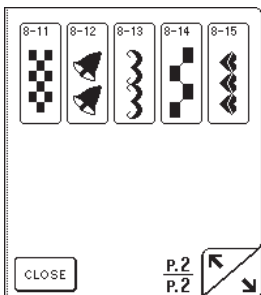
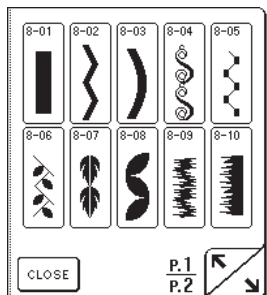
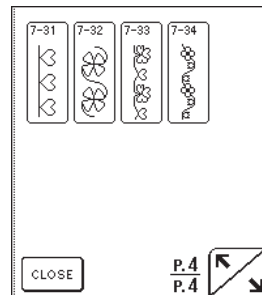
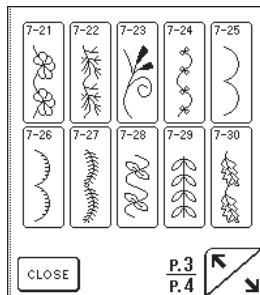
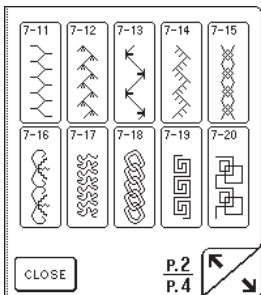
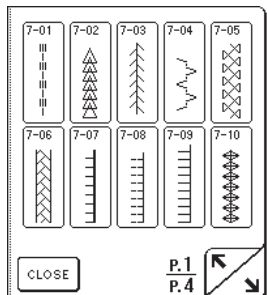
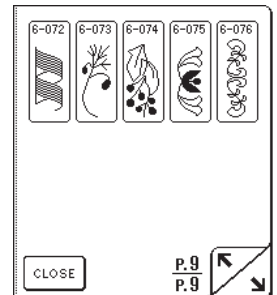
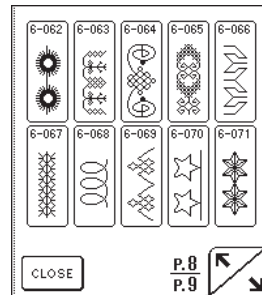
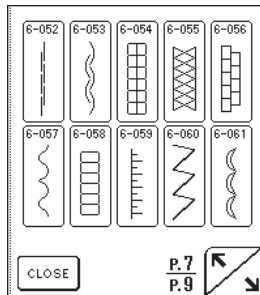
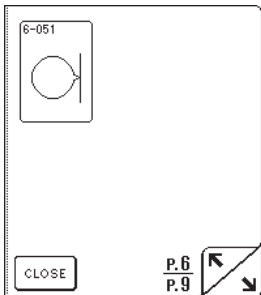
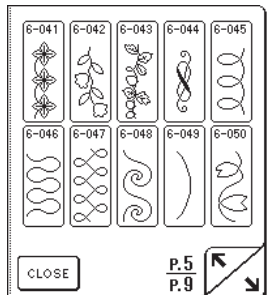
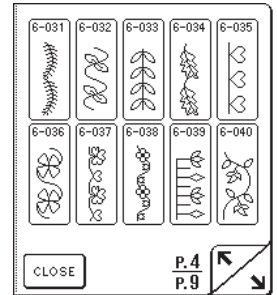
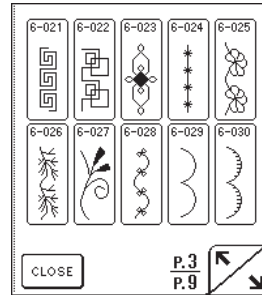
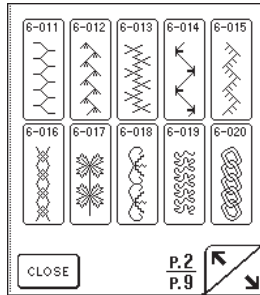
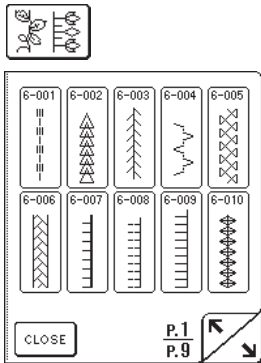
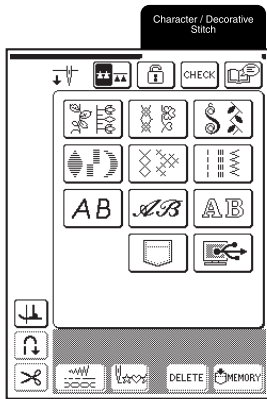

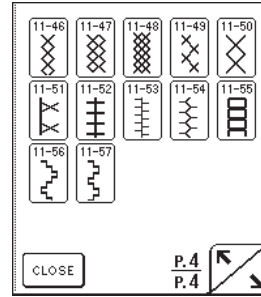
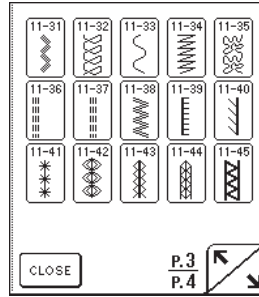
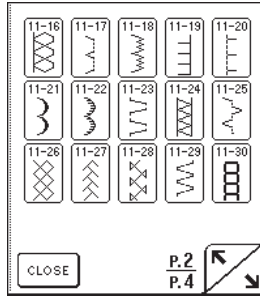
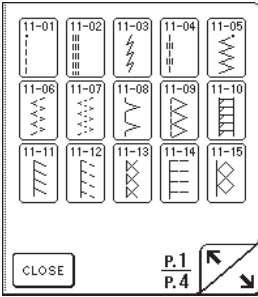

**AB**

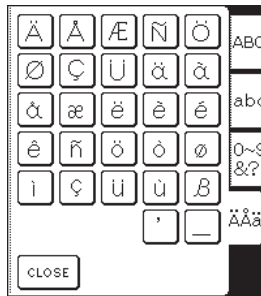
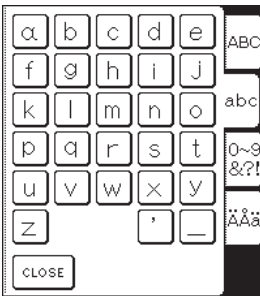
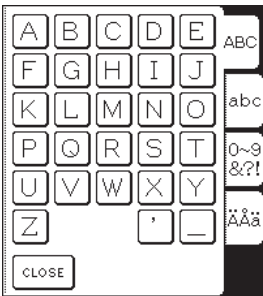

*AB*

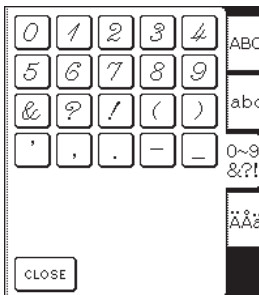
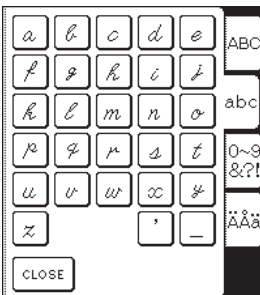
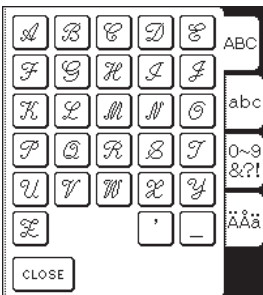

**AB**

